

2014 EDITION

3"-64"

# FLANGED DI PIPE

DUCTILE IRON



INDUSTRIAL APPLICATIONS, WATER & WASTEWATER

**MORE  
THAN  
JUST  
PIPE.**

**U.S.  
PIPE**

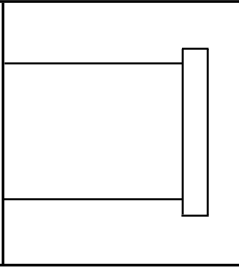

# FLANGED DI PIPE



2014 EDITION

P 2

## Table of Contents

Flanged Pipe for Water and Other Liquids	3
Ductile Iron Flanged Pipe With Threaded Flanges-Flanged Details	5
Ductile Iron Flanged Pipe With Threaded Flanges	6
Products for Water, Wastewater and Fire Protection	7

# FLANGED DI PIPE



2014 EDITION

P 3

## Flanged Pipe for Water and Other Liquids

Flanged pipe and fittings are typical components in rigid piping systems. Such systems are particularly suited for above ground installation in the following: water filtration plants, sewage disposal plants, wastewater treatment plants, pumping stations and industrial plants, per **AWWA C115/21.15**. The underground use of the flanged joint is not recommended due to the rigidity of the joint. Unequal settlement or other stressing of such piping may result in excessive strain on the flanges or the pipe due to excessive beam loadings.

### Flanged Pipe with Threaded Flanges

Pipe barrels conform to **ANSI/AWWA C151/A21.51**. Flanged pipe are fabricated by threading plain end pipe, screwing threaded flange(s) on and machine-tightening them. The bolt holes are aligned per **ANSI/AWWA C115/A21.15**. The plain end and the flange are then faced to insure that the flange is perpendicular to the pipe axis and the pipe/flange interface is flush. Pipe barrels and flanges have a taper pipe thread (NPT) in accordance with **ANSI B1.20.1**, with thread diameters adapted to Ductile Iron pipe standard outside diameters. Threaded pipe and threaded flanges are individually fitted and the flanges are not interchangeable. U.S. Pipe only uses and recommends ductile iron flanges, although **ANSI/AWWA C115/A21.15** currently allows gray iron flanges.

**Flanged pipe are furnished with a maximum length of 19' - 6". The minimum length varies by pipe size and can be found in the table on page 7.**

The minimum class thickness for Ductile Iron flanged pipe to be threaded is Special Thickness Class 53 for sizes up through 54" and pressure class 350 for 60" and 64" sizes. Greater pipe wall thicknesses can be furnished if so ordered.

Weights of flanged pipe shown are subject to a minus tolerance of not more than 10% for individual pieces. To obtain the weight of a short flanged pipe, calculate the pipe weight for the length from face to face of the flanges and add the weight of two flanges.

Pipe may be furnished with one end flanged and the other end with a TYTON<sup>®</sup>, TR FLEX<sup>®</sup>, HP LOK<sup>™</sup>, or MJ bell. Special ends such as grooved, shouldered, spigot restrained, and MJ HARNESS-LOK, are also available.

Thrust Type Wall Collars are available for wall penetrations and thrust restraint. See U.S. Pipe's THRUST COLLAR/WALL PIPE submittal for more information.

The Foreword of **ANSI/AWWA C115/A21.15** lists the required information and the options which if desired must be specified on the purchase order for flanged pipe, such as size and finished length. See the standard for more details.

### ANSI/AWWA Standards

#### **ANSI/AWWA C115/A21.15 Flanged Ductile-Iron Pipe with Ductile-Iron or Gray-Iron Threaded Flanges.**

Threaded flanged pipe conform to the requirements of ANSI/AWWA C115/A21.15.

#### **ANSI/AWWA C151/A21.51 Ductile Iron Pipe, Centrifugally Cast, for Water.**

Ductile Iron pipe used for flanging are centrifugally cast in accordance with the requirements of ANSI/AWWA C151/A21.51.

#### **ANSI/AWWA C104/A21.4 Cement-Mortar Lining for Ductile-Iron and Gray-Iron Fittings for Water.**

Cement-Mortar Lining with asphaltic coating inside in accordance with ANSI/AWWA C104/A21.4.

## Flanged Pipe for Water and Other Liquids (cont.)

### Flange Compatibility and Pressure Ratings

The ANSI/AWWA C115/A21.15 Flanged Ductile-Iron Pipe with Ductile-Iron or Gray-Iron Threaded Flanges standards conform to the drilling and facing of ANSI B16.1 Class 125 flanges. This B16.1 Class 125 designation leads some to conclude that these AWWA flanges are only rated at 125 psi service which is not correct. Note Pressure Ratings on page 6. These ratings are at ambient temperatures with at least a 2:1 factor of safety. Special gaskets such as U.S. Pipe's **FULL FACE FLANGE-TYTE™** or **RING FLANGE-TYTE™** Gaskets are required for operating pressures greater than 250 psi for sizes 04" - 24".

(Flanges of Ductile Iron fittings meeting the requirements of **ANSI B16.1 Class 250** cannot be joined with **ANSI/AWWA C115/A21.15**.)

### Coating Systems

Unless otherwise specified, flanged pipe will be furnished with a standard thickness cement-mortar lining with asphaltic coating inside and outside. Primer coatings are available upon request. Please contact U.S. Pipe Special Projects Department at 866-DIP-PIPE for a list of available interior linings and exterior primers.

### Special Service Requirements

When requesting prices for flanged piping other than water service, please furnish complete information regarding the type of material to be conveyed, composition, concentration, pH, pressure and temperature.

### Installation

U.S. Pipe recommends the use of **FULL FACE FLANGE-TYTE™** Gaskets or **RING FLANGE-TYTE™** Gaskets with Ductile Iron flanged joint products supplied by U.S. Pipe. These gaskets were designed specifically for the unique surface of Ductile Iron. Flat rubber gaskets are NOT considered equal in performance and may not provide the sealing capability the project requires. In addition, their use could result in unintended damage to the flanges and threads of the fabricated pipe by applying excess torque to the bolts/flanges in order to seal the joint. Please refer to U.S. Pipe's **FULL FACE FLANGE-TYTE™** or **RING FLANGE-TYTE™** Gaskets at [www.uspipe.com](http://www.uspipe.com).

The use of flanged joints underground is not recommended because of the rigidity of the joint.

Flanged faces should bear uniformly on the gasket, and the bolts should be tightened in a progressively crisscrossed pattern, such as by tightening the bottom bolt first; then, the top bolt; next, the bolts at either side; and finally, the remaining bolts. This process should be repeated until all bolts are adequately tightened.

Users of flanged piping should be careful to prevent bending or torsional strains from being applied to flanges or flanged appurtenances. Piping systems must be designed so that piping connected to flanges is properly anchored, supported, or restrained to prevent breakage of flanges and flanged fittings or appurtenances.

Impact wrenches cannot be used in many cases when assembling flanged joints due to the many variations of flange shroud diameters and impact wrench socket dimensions, in combination with nut configurations (heavy or regular hex).

**CAUTION:** U.S. Pipe does not recommend the practice of assembling threaded flanges on pipe in the field.

# FLANGED DI PIPE



2014 EDITION

P 5

## Ductile Iron Flanged Pipe With Threaded Flanges Flange Details

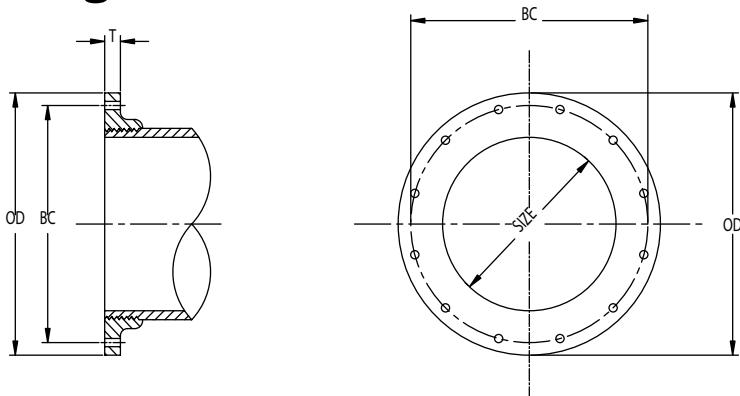

SIZE Inches	DIMENSIONS Inches					
	OD	BC	T	BOLT HOLE Diameter	BOLT Diameter & Length	QTY. OF BOLTS
3	7.50	6.00	.75 ± .12	3/4	5/8 x 2-1/2	4
4	9.00	7.50	.94 ± .12	3/4	5/8 x 3	8
6	11.00	9.50	1.00 ± .12	7/8	3/4 x 3-1/2	8
8	13.50	11.75	1.12 ± .12	7/8	3/4 x 3-1/2	8
10	16.00	14.25	1.19 ± .12	1	7/8 x 4	12
12	19.00	17.00	1.25 ± .12	1	7/8 x 4	12
14	21.00	18.75	1.38 ± .19	1-1/8	1 x 4-1/2	12
16	23.50	21.25	1.44 ± .19	1-1/8	1 x 4-1/2	16
18	25.00	22.75	1.56 ± .19	1-1/4	1-1/8 x 5	16
20	27.50	25.00	1.69 ± .19	1-1/4	1-1/8 x 5	20
24	32.00	29.50	1.88 ± .19	1-3/8	1-1/4 x 5-1/2	20
30	38.75	36.00	2.12 ± .25	1-3/8	1-1/4 x 6-1/2	28
36	46.00	42.75	2.38 ± .25	1-5/8	1-1/2 x 7	32
42	53.00	49.50	2.62 ± .25	1-5/8	1-1/2 x 7-1/2	36
48	59.50	56.00	2.75 ± .25	1-5/8	1-1/2 x 8	44
54	66.25	62.75	3.00 ± .25	2	1-3/4 x 8-1/2	44
60	73.00	69.25	3.12 ± .25	2	1-3/4 x 9	52
64	80.00	76.00	3.38 ± .25	2	1-3/4 x 9	52

**LENGTH TOLERANCE:** Pipe face-to-face dimensions conform to a tolerance of  $\pm .12$ " for sizes 3"-64"

**FLANGES:** The bolt circle and bolt holes of these flanges match those of **ANSI/AWWA C115/A21.15** and Class 125 flanges shown in ANSI B16.1 and can be joined with A21.15 and Class 125 B16.1 flanges. The flanges do not match the Class 250 flanges shown in ANSI B16.1 and cannot be joined with Class 250 B16.1 flanged fittings and valves. For technical information on Class 250 flanges see U.S. Pipe's Class 250 Flanges submittal document at [www.uspipe.com](http://www.uspipe.com).

**FACING:** Class 125 flanges are plain faced without projection and are furnished smooth or with shallow serrations.

**CERTIFICATION:** Complies with **ANSI/AWWA C115/A21.15 Flanged Ductile Iron Pipe**.

Bolts are normally not furnished by U.S. Pipe. Bolt data in the table is provided for information only. Bolts may be provided by U.S. Pipe upon request.

# FLANGED DI PIPE



2014 EDITION

P 6

## Ductile Iron Flanged Pipe With Threaded Flanges

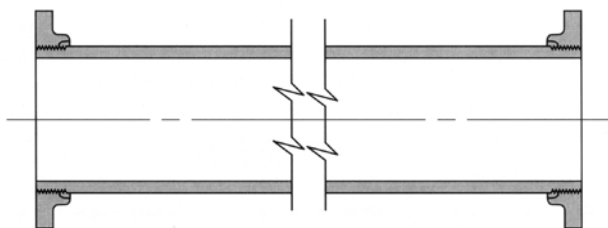

U.S. Pipe recommends the use of **FULL FACE FLANGE-TYTE™** Gaskets or **RING FLANGE-TYTE™** Gaskets with Ductile Iron flanged joint products supplied by U.S. Pipe. These gaskets were designed specifically for the unique surface of Ductile Iron. Flat rubber gaskets are **NOT** considered equal in performance and may not provide the sealing capability the project requires. In addition, their use could result in unintended damage to the flanges and threads of the fabricated pipe by applying excess torque to the bolts/flanges in order to seal the joint.

SIZE Inches	PRESSURE RATING psi	OUTSIDE DIAMETER Inches	MIN. WALL THICKNESS Inches	MAXIMUM LENGTH		WEIGHT Pounds		
				Feet	Inches	FLANGE Per Each†	PIPE W/O FLANGES Per Foot	PIPE W/ FLANGES Per Length
3	250	3.96	0.31	17'	6"	7	11.8	221
4	250 *	4.80	0.32	20'	0"	12	13.8	300
6	250 *	6.90	0.34	20'	0"	17	21.4	462
8	250 *	9.05	0.36	20'	0"	25	30.1	652
10	250 *	11.10	0.38	20'	0"	34	39.2	852
12	250 *	13.20	0.40	20'	0"	51	49.2	1086
14	250 *	15.30	0.42	19'	6"	69	60.1	1310
16	250 *	17.40	0.43	19'	6"	87	70.1	1541
18	250 *	19.50	0.44	19'	6"	89	80.6	1750
20	250 *	21.60	0.45	19'	6"	110	91.5	2004
24	250 *	25.80	0.47	19'	6"	153	114.4	2537
30	250	32.00	0.51	17'	6"	212	154.4	3126
36	250	38.30	0.58	17'	6"	324	210.3	4328
42	250	44.50	0.65	17'	6"	534	274.0	5863
48	250	50.80	0.72	19'	0"	646	346.6	7877
54	250	57.56	0.81	19'	0"	760	441.9	9916
60	250	61.61	0.83	19'	0"	1246	485.0	11707
64	250	65.67	0.87	19'	0"	1788	542.0	13874

\* U.S. Pipe rates its 4"-24" pipe for 350 psi service with use of the **FULL FACE FLANGE-TYTE™** or **RING FLANGE-TYTE™** Gasket.

†Weight subject to change depending upon flange manufacturer.

Contact U.S. Pipe if longer length is required.

For bolt hole details see page 5.

# FLANGED DI PIPE



2014 EDITION

P 7

## Minimum Lengths

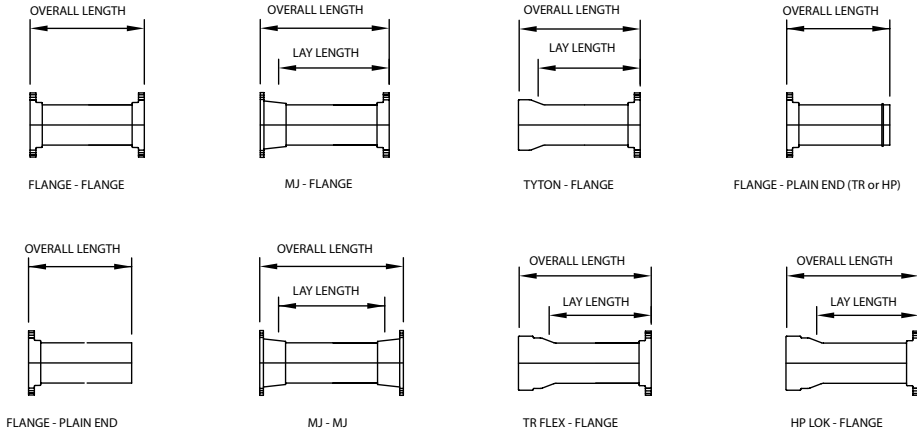

SIZE Inches	FLG - FLG	FLG - PE	MJ - FLG		MJ - MJ		TYTON® - FLG		TR FLEX® - FLG		FLG - PE (TR OR HP)	HP LOK® - FLG	
	O.A.	O.A.	O.A.	L.L.	O.A.	L.L.	O.A.	L.L.	O.A.	L.L.	O.A.	O.A.	L.L.
4	4.25	2.75	6.50	4.00	9.00	4.00	8.50	5.50	10.25	5.50	10.50	X	X
6	4.50	3.00	7.00	4.50	9.50	4.50	9.25	6.25	11.00	5.75	11.50	X	X
8	5.00	3.25	7.50	5.00	10.00	5.00	10.00	6.25	12.00	6.25	12.50	X	X
10	5.50	3.50	7.75	5.25	10.25	5.25	10.00	6.25	12.25	6.25	13.00	X	X
12	5.75	3.75	8.25	5.75	10.75	5.75	10.25	6.50	12.75	6.50	13.75	X	X
14	5.75	3.75	9.75	6.25	13.50	6.50	12.00	7.00	15.00	7.25	15.50	X	X
16	5.75	3.75	10.00	6.50	14.00	7.00	12.00	7.00	15.00	7.00	15.75	X	X
18	6.00	3.75	10.25	6.75	14.50	7.50	12.00	7.00	15.25	7.00	16.50	X	X
20	6.25	4.00	10.75	7.25	15.00	8.00	13.00	7.50	15.75	7.50	17.00	X	X
24	6.75	4.25	11.25	7.75	15.50	8.50	13.50	7.50	16.25	7.50	18.00	X	X
30	8.50	5.00	13.75	9.75	18.75	10.75	14.75	8.25	18.50	8.25	20.75	18.50	10.00
36	9.50	5.50	14.75	10.75	20.00	12.00	16.00	9.00	19.75	9.00	22.50	19.75	11.00
42	10.50	6.00	15.75	11.75	21.00	13.00	18.25	10.25	19.75	10.25	20.25	19.75	10.50
48	10.75	6.25	16.00	12.00	21.00	13.00	18.75	10.25	20.25	12.25	19.00	20.25	10.50
54	12.00	6.75	X	X	X	X	22.25	13.00	21.50	12.75	20.75	21.50	11.50
60	12.50	7.00	X	X	X	X	21.75	11.75	21.75	11.75	22.50	21.75	11.75
64	13.00	7.25	X	X	X	X	23.00	12.50	23.00	12.50	23.25	23.00	13.00

*Lengths shown are subject to manufacturing tolerances. If exact lengths are critical, please contact U.S. Pipe Special Projects Department.*

*Flanges and MJ Bells should normally be specified as "tapped for studs" for minimum pieces in order to be able to assemble the joints.*

*If shorter lengths are required, please contact U.S. Pipe Customer Service.*

*All lengths for MJ bells are based on threaded-on MJ bells. Lengths may vary if cast MJ pipe is used.*

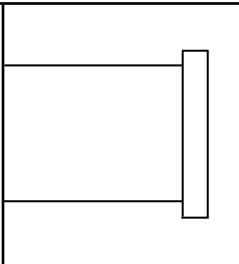

# FLANGED DI PIPE



2014 EDITION

P 8

## Products for Water, Wastewater and Fire Protection

Ductile Iron Pipe	SIZE RANGE
TYTON JOINT® Pipe	3"-64" Ductile Iron
Mechanical Joint Pipe	4"-12" Ductile Iron
TR FLEX® Pipe	4"-64" Ductile Iron
HP LOK™ Restrained Joint	30"-42"
Flanged Pipe	4"-64" Ductile Iron
USIFLEX® Boltless Flexible Joint Pipe — for Subaqueous Installations	4"-48" Ductile Iron
<b>Restrained Joints</b>	
TR FLEX® Pipe	4"-64" Ductile Iron
HP LOK™ Restrained Joint	30"-42"
MJ FIELD LOK® Gaskets	4"-24"
FIELD LOK 350® Gaskets	4"-24"
FIELD LOK® Gasket	30" & 36"
TR FLEX GRIPPER® Rings	4"-36" Ductile Iron
TR TELE FLEX® Assemblies	4"-24" Ductile Iron
<b>Ductile Iron Fittings</b>	
TYTON® Fittings	14"-64" Ductile Iron
TRIM TYTON® Fittings	4"-12" Ductile Iron
TR FLEX® Fittings and TR FLEX® Telescoping Sleeves	4"-64" Ductile Iron
Mechanical Joint Fittings	3"-48" Ductile Iron
TRIM TYTE® MJ Fittings	3"-48" Ductile Iron
Flanged Fittings	3"-64" Ductile Iron
XTRA FLEX® Couplings	4"-24" Ductile Iron
<b>Miscellaneous Products</b>	
PROTECTO 401™ Lined Ductile Iron Pipe for Domestic Sewage and Industrial Wastes	4"-64" Ductile Iron
RING FLANGE-TYTE™ Gaskets	4"-36"
FULL FACE FLANGE-TYTE™ Gaskets	4"-64"
Saddle Outlets	Various Ductile Iron
Welded Outlets	Various Ductile Iron
Polyethylene Encasement	4"-64"

*Our products are manufactured in conformance with National Standards so that our customers may be assured of getting the performance and longevity they expect. Use of accessories or other appurtenances that do not comply with recognized standards may jeopardize the performance and longevity of the project.*





*All U.S. Pipe brochures and/or products are  
subject to change without further notice.*

P.O. BOX 10406  
BIRMINGHAM, AL 35202  
866.DIP.PIPE (866.347.7473)  
FAX: 205.254.7165  
EMAIL: [INFO@USPIPE.COM](mailto:INFO@USPIPE.COM)  
[WWW.USPIPE.COM](http://WWW.USPIPE.COM)

**MORE  
THAN  
JUST  
PIPE.**

